

# AERO 42XL VACUUM PACKAGING MACHINE



## FEATURES:

- Standard with 1 seal bar (front): 420 mm
- Standard double seal (two wires). Optional without extra costs: Cut-off/Wide seal
- Seal bars easily removable for cleaning and maintenance purposes
- Pump capacity: 16 m<sup>3</sup>/h Busch vacuum pump
- Pump maintenance and cleaning program
- Machine cycle: 20-40 sec
- Standard Sensor control with a 3-program memory
- Easy control interface
- Standard soft air
- Deep-drawn stainless steel vacuum chamber
- Stainless steel exterior and transparent lid
- Comes with an insert plate for a faster cycle and product adjustment

## OPTIONS:

- 2nd seal bar (front and back)
- Liquid control

## ACCESSORIES:

- Inclined insert plate (for packing liquids)
- Food container adaptor
- Service kit for standard maintenance
- Trolley with shelf

## DESCRIPTION:

State of the art, innovative, robust machine with a slick design. Easy control interface. 3 adjustable setting programs. Standard Soft air. Precise vacuum settings with sensor pressure control. This table top model complies with CE standards.



## SEAL BAR CONFIGURATION:

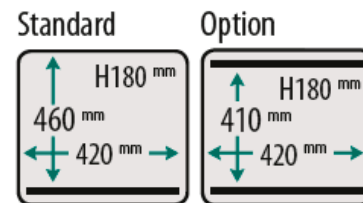

VACUUM PACKAGING MACHINE — AERO 42XL — SPEC SHEET



## Sales and Service Support

**Phone:**  
(07) 3806 5972

**Email:**  
sales@vacpac.com.au  
service@vacpac.com.au

## Visit our Showroom

Unit 3, 14-16 Cairns Street,  
Loganholme QLD, Australia  
4129

# AERO 42XL VACUUM PACKAGING MACHINE



## DIMENSIONS (IN MM)

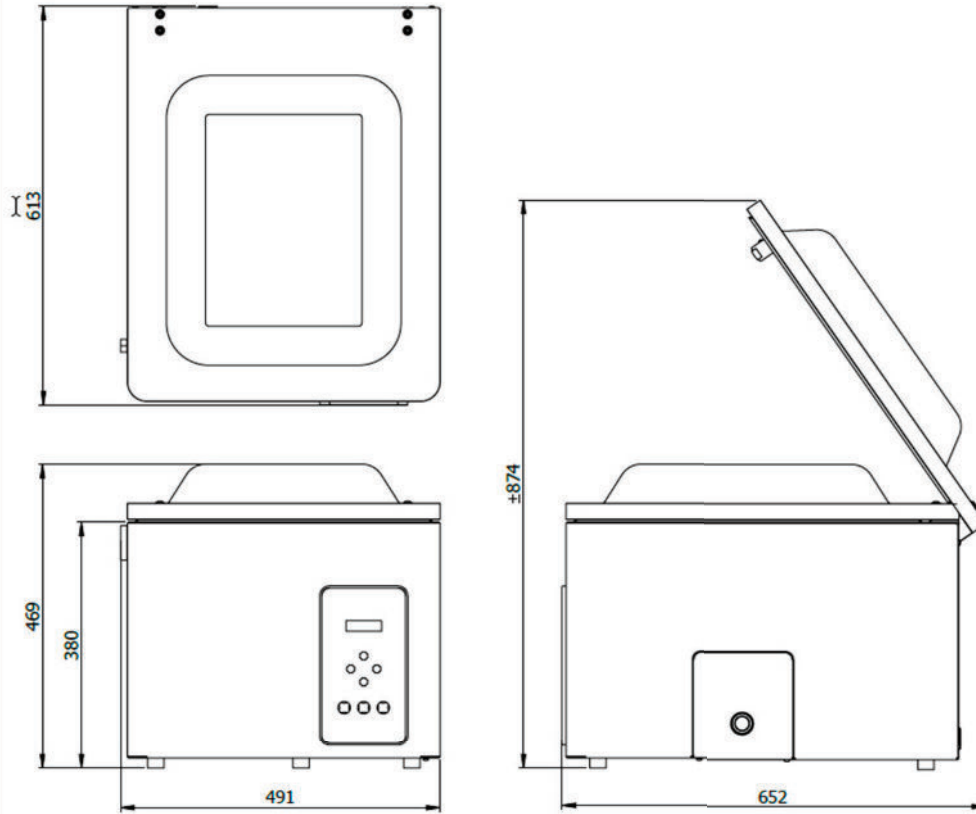

VACUUM PACKAGING MACHINE — AERO 42XL — SPEC SHEET

Model	Dimensions (mm)		Voltage* (Hz)	Pump capacity (m3/h)	Power (kW)	Weight (kg)
	Chamber (usable space) L x W x H	Machine L x W x H				
AERO 42XL	460 x 420 x 180	613 x 491x 469	230V-1-50	16	0,6 kW	68

\* Other voltages available



### Sales and Service Support

**Phone:**  
(07) 3806 5972

**Email:**  
sales@vacpac.com.au  
service@vacpac.com.au

### Visit our Showroom

Unit 3, 14-16 Cairns Street,  
Loganholme QLD, Australia  
4129