

BOXER 52 II VACUUM PACKAGING MACHINE



FEATURES:

- Standard with 2 seal bars (left-right): 2 x 410 mm
- Standard double seal (two wires). Optional without extra costs: Cut-off/Wide seal
- Seal bars easily removable for cleaning and maintenance purposes
- Pump capacity: 21 m³/h Busch vacuum pump
- Pump maintenance and cleaning program
- Machine cycle: 20-40 sec
- Standard Digital control with Time control and a 10-program memory
- Standard Soft Air to protect the product and vacuum bag
- Deep-drawn stainless steel vacuum chamber
- Stainless steel exterior and transparent lid
- Comes with an insert plate for a faster cycle and product adjustment

OPTIONS:

- 1-2 Cut off seal
- Sensor control/Advanced Control System
- Liquid control
- Gas flush

ACCESSORIES:

- Zebra ZD410 thermal label printer (only in combination with Advanced Control System)
- Inclined insert plate (for packing liquids)
- Food container adaptor
- Service kit for standard maintenance

DESCRIPTION:

The robust stainless steel Boxer 52 II vacuum packaging machine comes standard equipped with two seal bars, a Busch vacuum pump, and Digital control with a 10-program memory. This tabletop model complies with CE standards.



SEAL BAR CONFIGURATION:



Sales and Service Support

Phone:
(07) 3806 5972

Email:
sales@vacpac.com.au
service@vacpac.com.au

Visit our Showroom

Unit 3, 14-16 Cairns Street,
Loganholme QLD, Australia 4129

VACUUM PACKAGING MACHINE — BOXER 52 II — SPEC SHEET

BOXER 52 II VACUUM PACKAGING MACHINE



DIMENSIONS (IN MM)

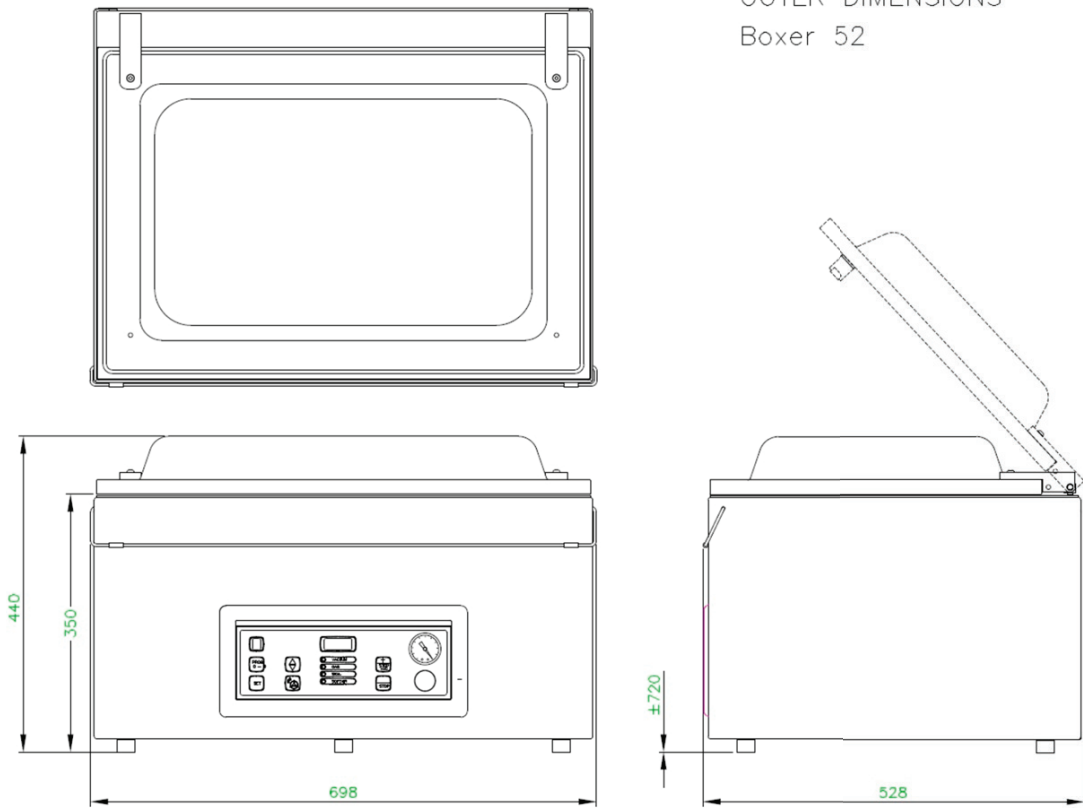

OUTER DIMENSIONS
Boxer 52

VACUUM PACKAGING MACHINE — BOXER 52 II — SPEC SHEET

Model	Dimensions (mm)		Voltage* (Hz)	Pump capacity (m3/h)	Power (kW)	Weight (kg)
	Chamber (usable space) L x W x H	Machine L x W x H				
Boxer 52 II	410 x 520 x 180	528 x 698 x 440	230V-1-50	21	0,75 – 1,0	81

* Other voltages available



Sales and Service Support

Phone:
(07) 3806 5972

Email:
sales@vacpac.com.au
service@vacpac.com.au

Visit our Showroom

Unit 3, 14-16 Cairns Street,
Loganholme QLD, Australia
4129