

JUMBO 35 VACUUM PACKAGING MACHINE



FEATURES:

- Standard with 1 seal bar (front): 350 mm
- Standard double seal (two wires)
- Optional without extra costs: Cut-off/Wide seal
- Seal bars easily removable for cleaning and maintenance purposes
- Pump capacity: 16 m³/h Busch vacuum pump
- Pump maintenance and cleaning program
- Machine cycle: 15-30 sec
- Standard Time control with a 1-program memory
- Deep-drawn stainless steel vacuum chamber
- Stainless steel exterior and transparent lid
- Comes with an insert plate for a faster cycle and product adjustment

OPTIONS:

- Sensor control

ACCESSORIES:

- Inclined insert plate (for packing liquids)
- Food container adaptor
- Service kit for standard maintenance
- Trolley with shelf

DESCRIPTION:

The robust, stainless steel Jumbo 35 vacuum packaging machine is standard equipped with a Busch vacuum pump and Time control with a 1 program memory . This table top model complies with CE standards.



SEAL BAR CONFIGURATION:

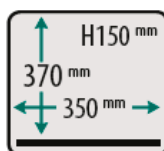

Sales and Service Support

Phone:
(07) 3806 5972

Email:
sales@vacpac.com.au
service@vacpac.com.au

Visit our Showroom

Unit 3, 14-16 Cairns Street,
Loganholme QLD, Australia 4129

VACPAC.COM.AU

VACUUM PACKAGING MACHINE – JUMBO 35 – SPEC SHEET

JUMBO 35 VACUUM PACKAGING MACHINE



DIMENSIONS (IN MM)

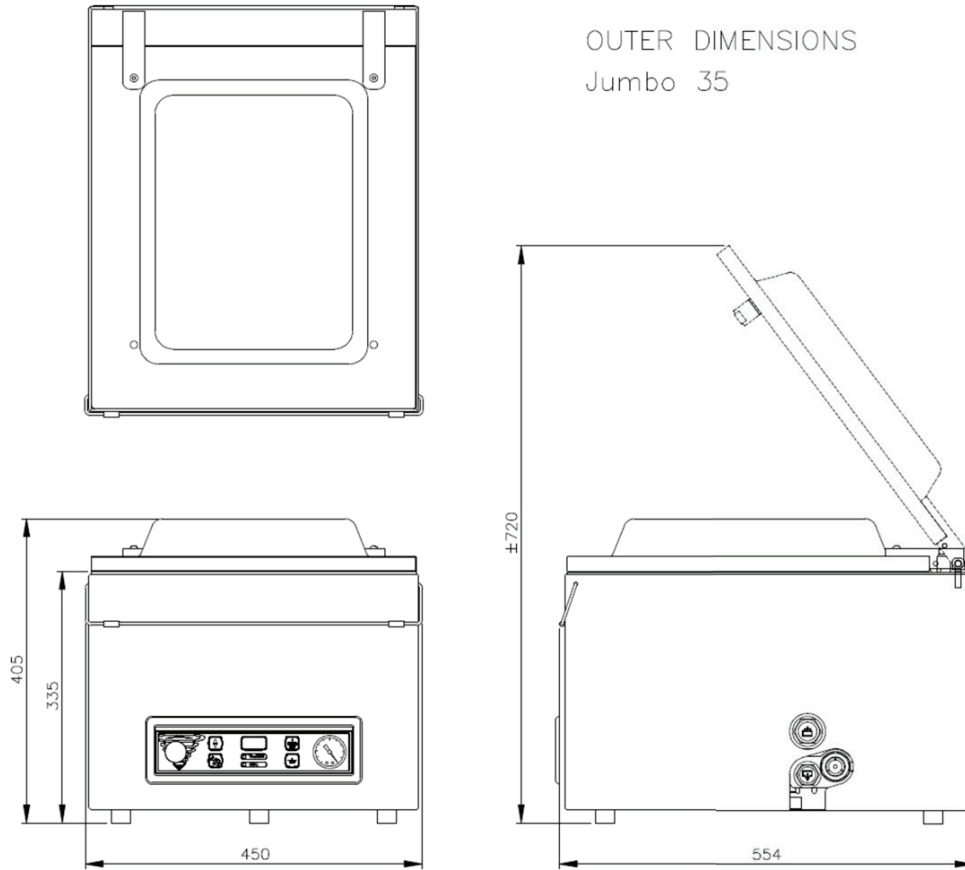

OUTER DIMENSIONS
Jumbo 35

VACUUM PACKAGING MACHINE — JUMBO 35 — SPEC SHEET

Model	Dimensions (mm)		Voltage* (Hz)	Pump capacity (m3/h)	Power (kW)	Weight (kg)
	Chamber (usable space) L x W x H	Machine L x W x H				
Jumbo 35	370 x 350 x 150	554 x 450 x 405	230V-1-50	16	0,6 kW	51

* Other voltages available



Sales and Service Support

Phone:
(07) 3806 5972

Email:
sales@vacpac.com.au
service@vacpac.com.au

Visit our Showroom

Unit 3, 14-16 Cairns Street,
Loganholme QLD, Australia
4129