

POLAR 2-75 VACUUM PACKAGING MACHINE



VACUUM PACKAGING MACHINE – POLAR 2-75 – SPEC SHEET



FEATURES:

- Standard with 2 seal bars (front-back): 2 x 620 mm
- Optional without extra costs: 2 seal bars of 840 mm (left-right)
- Standard double seal (two wires). Optional without extra costs: Cut off or Wide seal (10 mm)
- Silicone holders easily removable for cleaning and maintenance purposes
- Pump capacity: 160 m³/h Busch vacuum pump
- Pump maintenance and cleaning program
- Machine cycle: 15-40 sec
- Soft Air to protect the product and vacuum bag
- Standard Digital control with 10 program memory and Time control
- Flat work plate
- Comes with insert plates for a faster cycle and product adjustment
- Stainless steel exterior
- IP-65 classification

OPTIONS:

- 1-2 Cut off/Bi-active seal
- Sensor control, Advanced Control System (ACS), Liquid control
- Gas flush (including pressed air connection)
- Preparation for external pump
- Heating element for vacuum valve

ACCESSORIES:

- Zebra ZD410 thermal label printer (only in combination with ACS)
- Inclined insert plate
- Service kit for standard maintenance

DESCRIPTION:

The robust, stainless steel Polar 2 75 vacuum packaging machine is standard equipped with a Busch vacuum pump. This double chamber complies with CE standards.



SEAL BAR CONFIGURATION:

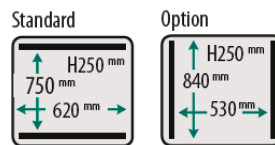

Sales and Service Support

Phone:
(07) 3806 5972

Email:
sales@vacpac.com.au
service@vacpac.com.au

Visit our Showroom

Unit 3, 14-16 Cairns Street,
Loganholme QLD, Australia 4129

POLAR 2-75 VACUUM PACKAGING MACHINE



DIMENSIONS (IN MM)

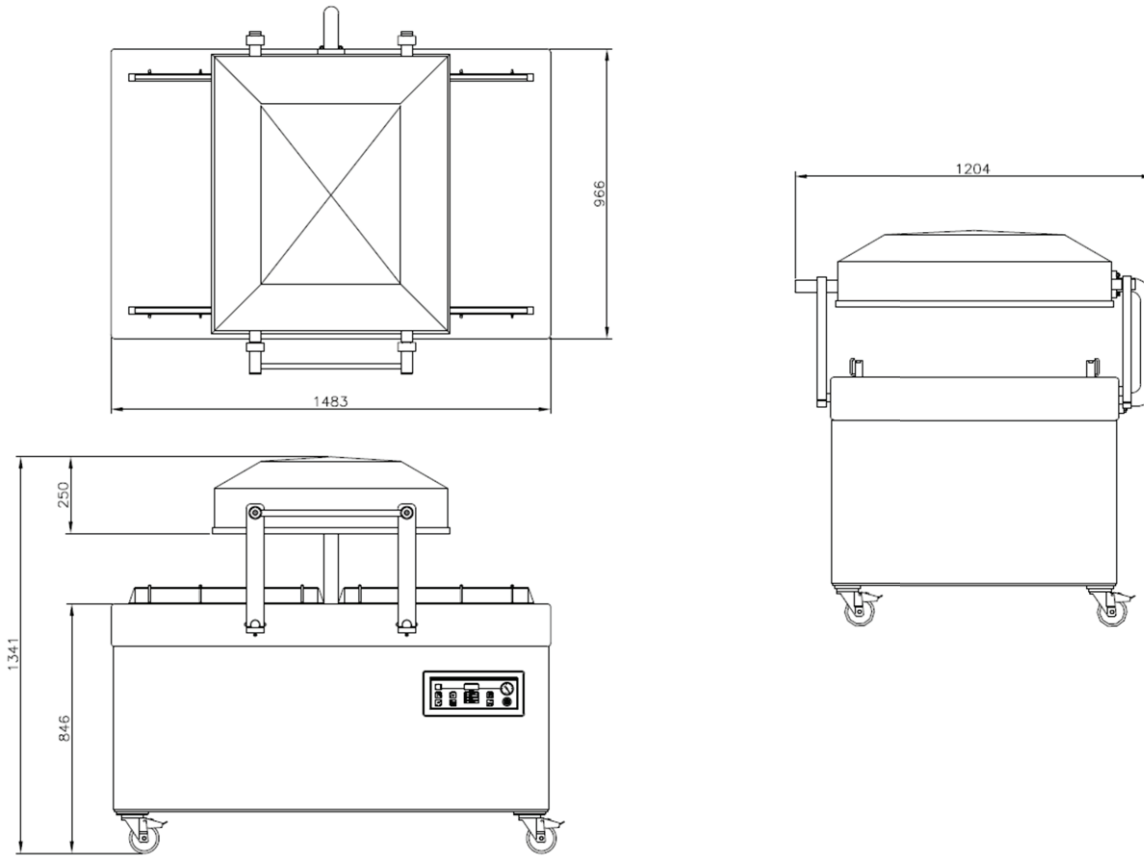

VACUUM PACKAGING MACHINE — POLAR 2-75 — SPEC SHEET

| Model | Dimensions (mm) | | Voltage* (Hz) | Pump capacity (m ³ /h) | Power (kW) | Weight (kg) |
|------------|----------------------------------|--------------------|---------------|-----------------------------------|------------|-------------|
| | Chamber (usable space) L x W x H | Machine L x W x H | | | | |
| Polar 2-75 | 750 x 620 x 250 | 1204 x 1483 x 1341 | 400V-3-50 | 160 | 5,5 – 9,0 | 537 |

* Other voltages available



Sales and Service Support

Phone:
(07) 3806 5972

Email:
sales@vacpac.com.au
service@vacpac.com.au

Visit our Showroom

Unit 3, 14-16 Cairns Street,
Loganholme QLD, Australia
4129